

RAY
VISIONS
Medical Imaging Devices
High Resolution Mini Gamma Cameras

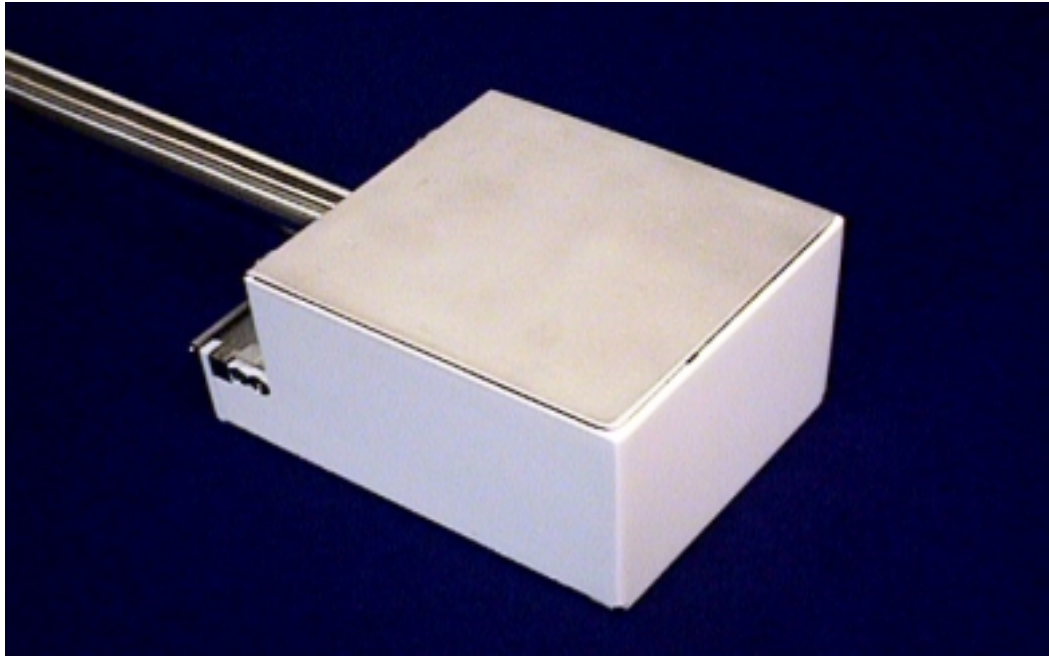

Multimodality Small Animal Imaging Systems

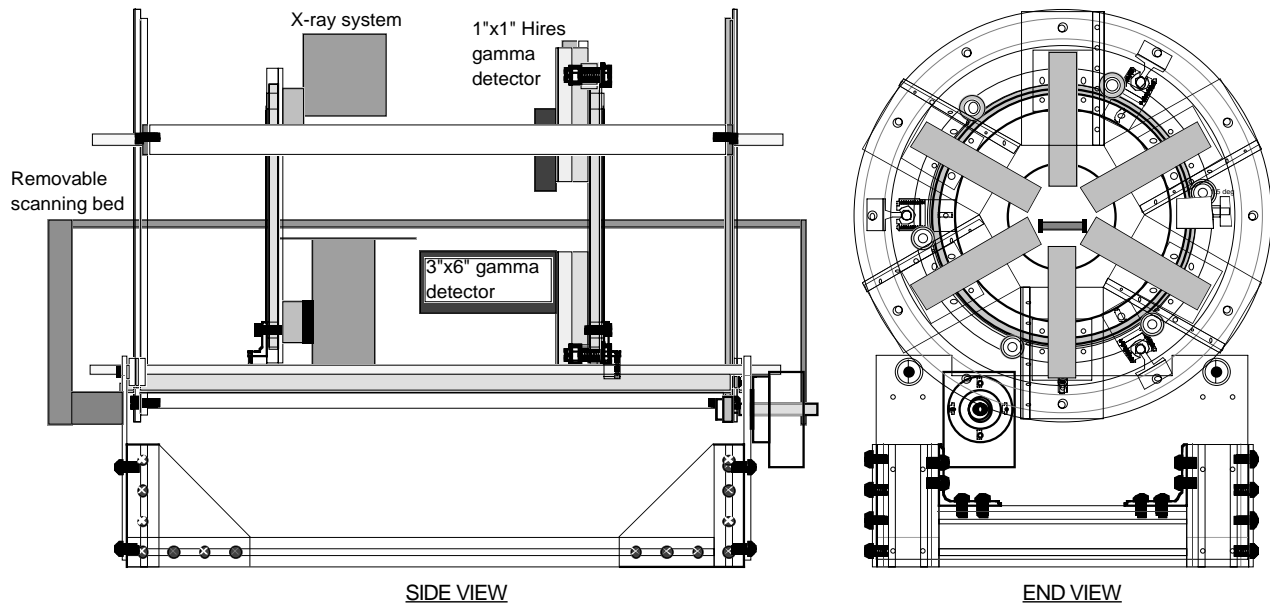

Ray Visions, Inc., 317 Blacksmith Arch, Yorktown, VA 23693 Ph/FAX 757-865-6442
sales@rayvisions.com, <http://www.rayvisions.com>

Based on technology originally developed at Jefferson Lab* *Ray Visions'* compact gamma cameras are a step ahead of standard nuclear imaging systems.

Advantages

Higher Sensitivity

Higher Resolution

<7mm dead space at edges

PET/SPECT in one instrument

Easier positioning

Integration with other imaging modalities

Variety of sizes available

Lower cost

Mobility

Finding Breast Cancer

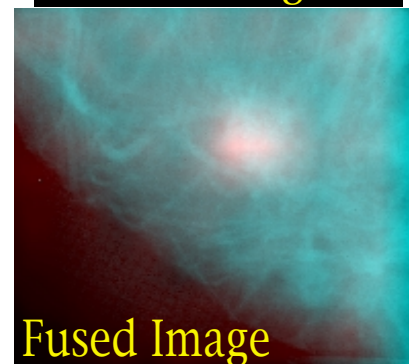
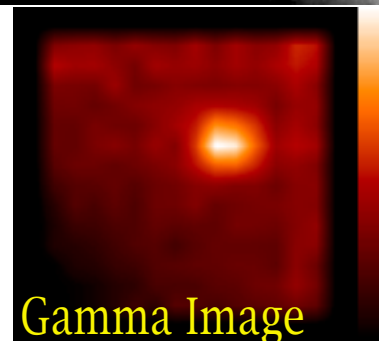
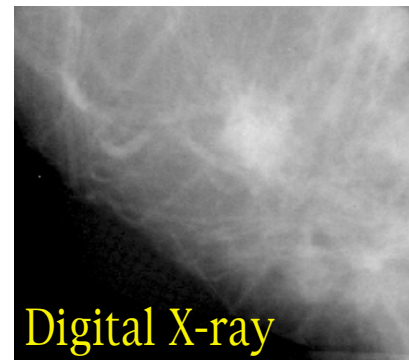

Standard Nuclear Imaging System



*The Southeastern Universities Research Association (SURA) operates the Thomas Jefferson National Accelerator Facility for the United States Department of Energy under contract DE-AC05-84ER40150.

From A.G. Weisenberger, et al., "A Combined Scintimammography / Stereotactic Core Biopsy Digital X-ray System," Proceedings IEEE NSS-MIC Conference, Lyon France, Oct. 2000.

Ray Visions, Inc., 317 Blacksmith Arch, Yorktown, VA 23693 Ph/FAX 757-865-6442
sales@rayvisions.com, <http://www.rayvisions.com>

Dual Modality Breast Biopsy System

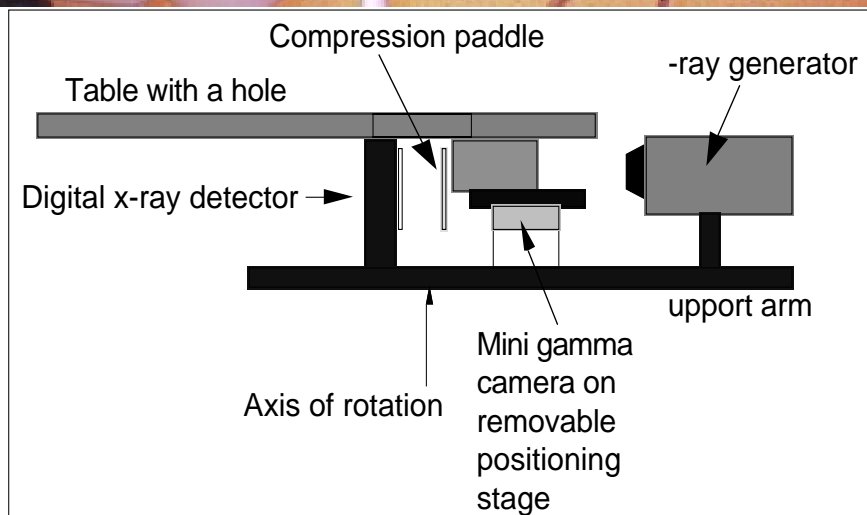
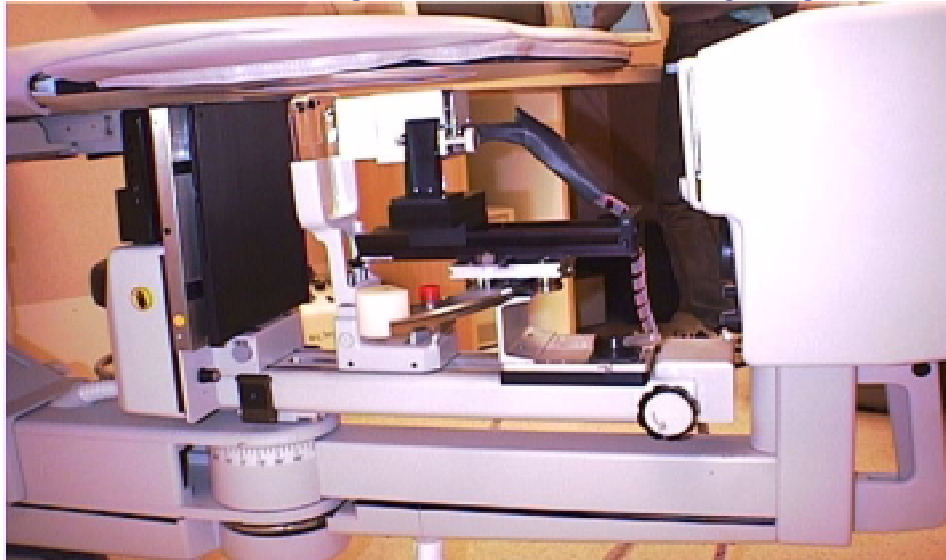

Compact gamma camera combined with a Fischer core biopsy table.

Current Clinical trials

25 cases

6 positive for tracer uptake

5 true positives from pathology

No false negatives

Tumors visible in < 3 minutes

Tumors as small as 3mm can be identified

Small Animal Multimodality Imaging Systems

SPECT

PET

CT

Ultrasound*

IR*

In one compact flexible
upgradable system for imaging
mice and rats

Example of studies which can be performed

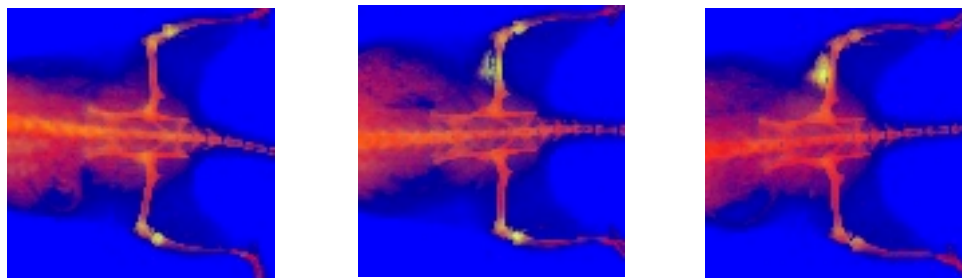

Dual-modality images of a rat at 12 (left), 18 (center), and 24 (right) days after injection with two different BMPs. The upper thigh received BMP-2, and progressive bone growth and increased MDP uptake were observed. The lower thigh, into which BMP-9 was injected, showed little bone growth or uptake of MDP. From M. Williams, et al., "Dual modality system for small animal imaging", RSNA Electronic Journal: <http://ej.rsna.org/ej3/0107-99.fin/dual99.htm>, 1999.

*Under development

Ray Visions, Inc., 317 Blacksmith Arch, Yorktown, VA 23693 Ph/FAX 757-865-6442
sales@rayvisions.com, <http://www.rayvisions.com>